

ADJUSTABLE PANEL DOLLY - PLDL-ADJ-8PS

APPROX WEIGHT: 44.97 lbs.
 DOES NOT INCLUDE WEIGHT OF POWER OR PACKAGING!!!

ANY ADDITIONS, DELETIONS, OR OMISSIONS MUST BE CORRECTED ON THIS DRAWING AS THIS DRAWING WILL BE CONSIDERED ALL INCLUSIVE

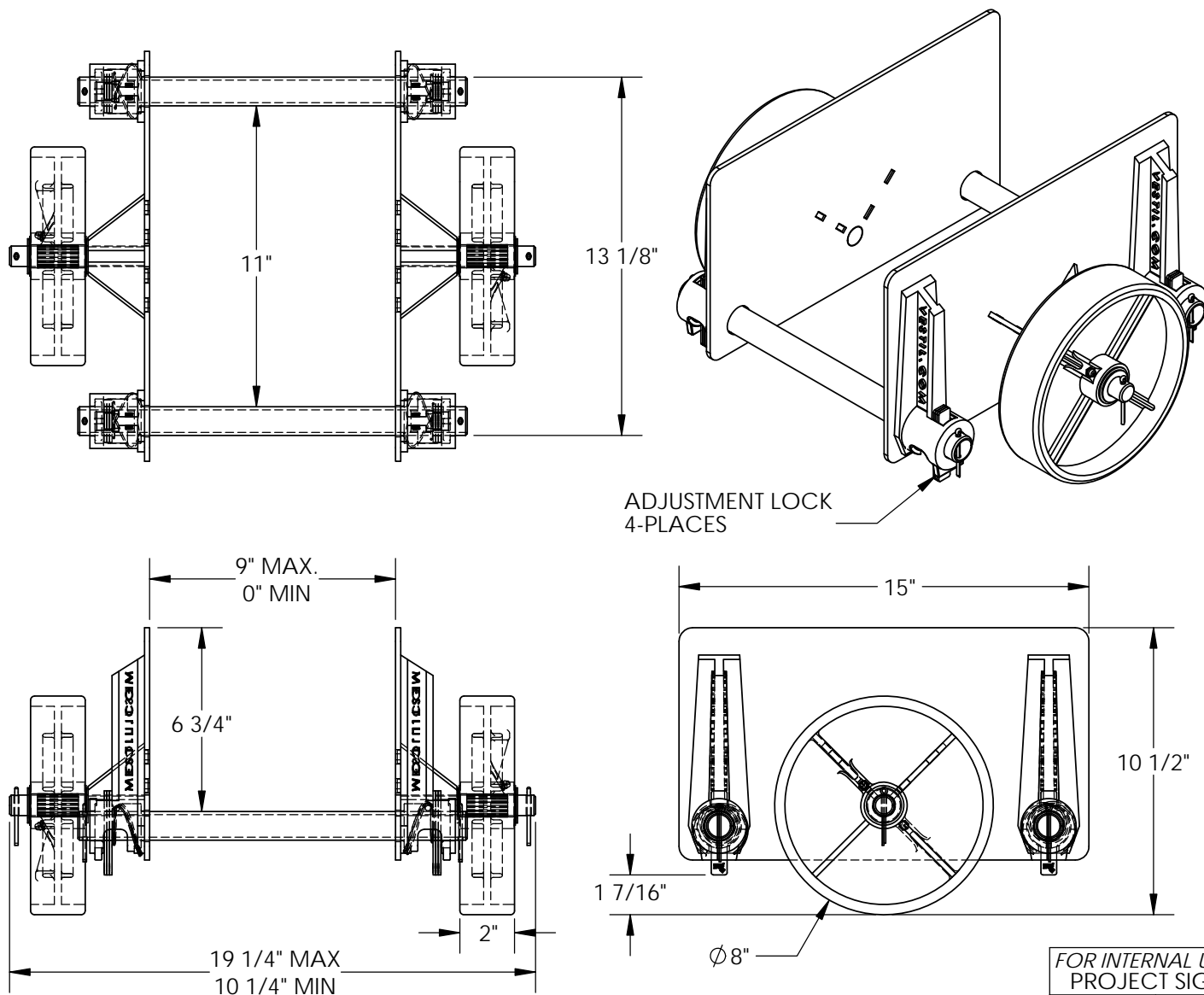

ALL GRAPHICS PROVIDED ARE FOR REFERENCE ONLY. IF CERTAIN DIMENSIONS ARE CRITICAL PLEASE VERIFY THOSE DIMENSIONS WITH YOUR SALESPERSON
 DIMENSION TOLERANCE $\pm 1/4"$

FOR INTERNAL USE ONLY PROJECT SIGN OFF	
SALES	
ENG.	
FAB.	
POWER	

STANDARD FEATURES

- MODEL NUMBER IS PLDL-ADJ-8PS
- CAPACITY IS: 1,000 LBS.
- OVERALL LENGTH IS: 15"
- OVERALL HEIGHT IS: 10 1/2"
- MAX. OVERALL WIDTH IS 19 1/4"
- MIN. OVERALL WIDTH IS 10 1/4"
- POSITIVE LOCKING CLUTCH PLATES ALLOW FOR EASIER RELEASE AND ADJUSTMENT
- DOLLY OPENING RANGE IS 0" - 9"
- STEEL CONSTRUCTION WITH TOUGH BAKED IN POWDERCOATED YELLOW FINISH
- (2) Ø8" x 2" POLY-ON-STEEL WHEELS

SPECIAL FEATURES

NONE

APPROVAL	I, THE UNDERSIGNED, AGREE THAT THE PRODUCT AS REPRESENTED SATISFIES DESIGN AND DIMENSION REQUIREMENTS. I ALSO ACKNOWLEDGE MY DUTY TO CONFIRM PRODUCT AND INSTALLATION COMPLIANCE WITH ALL APPLICABLE FEDERAL, STATE AND LOCAL REGULATIONS AND STANDARDS.	
	ANY MODIFIED UNITS ARE NON-RETURNABLE	
	[] As drawn [] As marked	
	Signed: _____	Date: _____
Printed Name: _____		
LEAD TIME WILL START UPON RECEIPT OF SIGNED APPROVAL DRAWING		

DISTRIBUTOR'S NAME:		P.O.#
VESTIL MANUFACTURING		X
DRAWN BY: TJM		W.O.#
DATE: 03/19/2012		X
REFERENCE: X	SCALE: 1:6	SALES: X
QUOTED LEAD TIME: X	QUOTE # X	FILE NAME:
		16-007-313